



Aurora Pro

4K Tri-Color UST Laser Projector

User Manual



Projectors
Support

Scan the QR code or visit our link to download the latest manual or watch the installation video.
nexigo.com/pages/projectors-support

User Manual

CONTENTS

Copyright	01
Disclaimer	01
What Does the Warranty Cover?	01
Important Safety Instructions	02
3D Safety Information	06
Maintenance	07
Welcome to the NexiGo Family!	08
Contact Information	08
Product Features	09
What's in the Box?	11
Projector Diagram	11
Connectors and Ports	13
Remote Introduction	14
Remote Control Pairing	15
Specifications	16
Installation	17
Image Adjustment	20
Projector Distance & Size	23
Quick Start Guide	24
Shutting Down the Projector	28
File Manager	29
System Settings	31
Multiscreen Connections	43
Amazon Alexa Voice Control Setup	47
Troubleshooting	51
Dolby Atmos / Dolby Vision	54
FCC Requirement	55
CE Conformity for European Countries	56

COPYRIGHT

Copyright 2024 by NexiGo Corporation. All rights reserved. No part of this publication may be reproduced, distributed, transmitted, stored in a retrieval system, or translated into any language or computer language, in any form or by any means, electronic, mechanical, magnetic, optical, chemical, manual, or otherwise, without the prior written permission of NexiGo Corporation.

DISCLAIMER

NexiGo Corporation makes no representations or warranties, either expressed or implied, regarding the contents of this publication. Specifically, NexiGo Corporation disclaims any warranties of merchantability or fitness for a particular purpose. Furthermore, NexiGo Corporation reserves the right to revise this publication and to make changes to the contents from time to time without any obligation to notify any person of such revisions or changes.

WHAT DOES THE WARRANTY COVER?

For specific warranty policies, please refer to the NexiGo official website: <https://www.nexigo.com/pages/warranty-policy>.

IMPORTANT SAFETY INSTRUCTIONS

PLEASE READ THE FOLLOWING SAFETY INSTRUCTIONS BEFORE YOU START USING THE PROJECTOR.

- Read the user manual in full before operating your projector and make sure to save it for future reference. Follow all instructions provided, failure to do so may result in the loss of the device or injury.
- This appliance can be used by children aged from 8 years and above and persons with reduced physical, sensory or mental capabilities or lack of experience and knowledge if they have been given supervision or instruction concerning use of the appliance in a safe way and understand the hazards involved. Children shall not play with the appliance. Cleaning and user maintenance shall not be made by children without supervision.

CHILD SAFETY MEASURES

- Children should not play with this appliance. Cleaning and user maintenance should not be made without direct supervision by an adult.
- Children less than 3 years of age should be kept away from this device unless continuously supervised.
- Children from 3 to 8 years of age should not plug in, regulate, clean, or perform any type of maintenance on this device.
- Children from 3 to 8 years of age shall only switch the appliance on / off after all the following safety precautions have been met:
 1. The product has been placed or installed in its intended operating position.
 2. The child has direct supervision or has been given full instructions on how to use the device safely.
 3. The child is capable of understanding the hazards involved.

OPERATIONAL SAFETY MEASURES

- For appliances having a specially prepared cord, if the supply cord is damaged, it must be replaced by a special cord or assembly available from the manufacturer or its service agent.
- To ensure the projector is operating smoothly and is protected from any potential overheating issues, make sure to install the projector in a location that does not block ventilation.
- To reduce the risk of fire and / or electric shock, **do not** expose the projector to moisture or liquids.
- **Do not** install the projector near heat sources or any other appliance that emits heat.
- **Do not** allow small objects to enter the projector. They may cause the projector to short circuit, which could start a fire or create an electric shock.
- **Do not** use the projector under the following conditions:
 - In extremely hot, cold, or humid environments.
 - (i) Ensure that the ambient room temperature is within 32°F-104°F (0°C-40°C)
 - (ii) Ensure that the relative humidity is ~30% - ~85%
 - In areas susceptible to excessive dust and dirt.
 - Near any appliance generating a strong magnetic field.
 - In direct sunlight.
- **Do not** use the projector if it has been physically damaged or abused. Physical damage / abuse could include (but is not limited to) the following circumstances:
 - The projector has been dropped.
 - The power supply cord or plug has been damaged.
 - Liquid has been spilled onto/into the projector.
 - The projector has been exposed to rain or moisture.
 - Something has fallen into the projector, or something is loose inside.
- **Do not** place the projector on an unstable surface. The projector may fall over, resulting in injury or damage to the unit.

- **Do not** block the light coming out of the projector lens when in operation. Objects in the light's path may melt, cause burns, or start a fire.
- **Do not** open or disassemble the projector, as this may result in an electrical shock.
- **Do not** attempt to service the unit yourself. Opening the unit may expose you to dangerous voltages and/or other hazards. The unit should only be repaired by the manufacturer or its service agent.
- Only use attachments / accessories directly specified by the manufacturer.
- **Do not** look straight into the projector lens during operation. Excessively bright lighting has been shown to harm vision under some circumstances.
- When switching the projector off, please ensure the cooling cycle has been completed before disconnecting the power. Allow at least 90 seconds for the projector to cool down.
- **Do not** use a power source with a voltage other than what is specified in this manual.
- Disconnect the power plug from the AC outlet if the product is not being used for a long period of time.
- **Do not** set up the projector in areas where it might be subjected to vibration or shock.
- **Do not** touch the lens with your bare hands.
- Remove the battery / batteries from the remote control before storage. If the battery / batteries are left in the remote for a long period of time, they may leak.
- **Do not** use or store the projector in places where smoke may be present, as it can negatively affect the quality of the projector's performance.
- Please refer to the manual for how to properly install your projector, as nonstandard installation may affect the projector's performance.
- Use a power strip and / or surge protector with this device. Power outages and / or brownouts can damage your device.
- When installing or adjusting a ceiling or wall mount, do not use adhesives, oils, and / or lubricants. These may cause the projector case

to crack and allow it to fall from its ceiling mount causing damage to the device and / or serious injury.

- Do not stand the projector vertically. Doing so may cause the projector to fall over, causing damage and / or injury.
- While the projector is operating, you may notice hot air and a strong odor emanating from its ventilation grill. This is normal and not a malfunction.

CLEANING THE PROJECTOR

- Turn off the projector and unplug the power plug from the AC outlet before cleaning the unit.
- Use a soft, dry cloth with mild detergent to clean the product housing. Do not use harsh cleaners, waxes, or solvents to clean the unit.

PHOTOSENSITIVE SEIZURE WARNING

- Some viewers may experience a medical issue such as epileptic seizure or stroke when exposed to flashing images and / or lights displayed by this device. If you suffer from or have a family history of epilepsy or stroke, please consult with a medical specialist before using the projector.



Warning: Avoid eye exposure at a distance of less than 1m / 3.28ft.

Avertissement: Évitez l'exposition oculaire à une distance inférieure à 1m / 3.28ft.

3D SAFETY INFORMATION

- Children and teenagers may be more susceptible to health issues when viewing 3D projections and should be closely supervised to ensure they are not being affected.
- Pregnant women, the elderly, people who are sleep-deprived, people under the influence of alcohol, and those more prone to serious medical conditions are recommended to avoid using the projector's 3D functionality.
- Watching 3D projections while wearing 3D glasses for an extended period of time may cause headaches or fatigue. If you experience a headache, noticeable signs of fatigue, or dizziness, stop viewing the 3D projection and rest.
- If you experience any of the following symptoms, stop viewing the 3D projection immediately and consult a medical specialist: (1) altered vision; (2) light-headedness; (3) dizziness; (4) involuntary movements such as eye or muscle twitching; (5) confusion; (6) nausea; (7) loss of awareness; (8) convulsions; (9) cramps; and / or (10) disorientation. Children and teenagers may be more likely than adults to experience these symptoms. Parents should monitor their children and ask whether they are experiencing these symptoms.
- Watching 3D projections may also cause motion sickness, perceptual after-effects, disorientation, eye strain, and decreased postural stability. It is recommended that users take frequent breaks to reduce the possibility of these effects. If your eyes show signs of fatigue or dryness, or if you show any of the above symptoms, immediately stop using this device and do not resume using it until at least 30 minutes after the symptoms have subsided.
- **Do not** place your 3D projector near open stairwells, cables, balconies, or other objects that can be tripped over, run into, knocked down, broken, or in areas with fall hazards.
- Watching 3D projections while sitting too close to the screen for an extended period of time may damage your eyesight. The ideal viewing distance is at least three times the screen height. It is recommended that the viewer's eyes are level with the center of the screen.
- **Do not** use the 3D glasses for any other purpose than for watching 3D projections.

MAINTENANCE

GENERAL PRECAUTIONS

- Make sure the projector is turned off and the power cable is unplugged from the power outlet.
- Never remove any parts from the projector. Contact Customer Support when any part of the projector needs replacing.
- Never spray or pour any liquid directly onto the case.
- Handle the projector with care, as a darker-colored projector, if scuffed, may show marks more clearly than a lighter-colored projector.

CLEANING DISCLAIMER

- It is not recommended to use any ammonia or alcohol-based cleaners on the lens or case. Some chemical cleaners have been reported to damage the lens and/or case of the projector.
- NexiGo will not be liable for damage resulting from use of any ammonia or alcohol-based cleaners.

CLEANING THE LENS

- Use a canister of compressed air to remove dust.
- If the lens is still not clean, use lens-cleaning paper or moisten a soft cloth with lens cleaner and gently wipe the surface.

CAUTION: Never rub the lens with abrasive materials.

STORING THE PROJECTOR

If you intend to store the projector for an extended period:

- Ensure the temperature and humidity of the storage area are within the recommended range (-4°F-131°F, 30%~85% relative humidity).
- Retract the adjuster foot on the bottom of the projector.
- Remove the batteries from the remote control.
- Pack the projector in its original packaging or equivalent.

WELCOME TO THE NEXIGO FAMILY!

Thank you for choosing the NexiGo 4K Tri-Color UST Laser Projector! You are now part of an exclusive club: the NexiGo family! It's our job to make sure you enjoy your membership. If you have any problems, please contact us any time at cs@nexigo.com for further assistance.

From all of us here at NexiGo, we want to thank you for your trust in us. We look forward to serving you again in the near future.

Sincerely,
The NexiGo Team

CONTACT INFORMATION

Website: www.nexigo.com

Manufacturer: Nexight INC

E-mail: cs@nexigo.com

Tel: +1(458) 215-6088

Address: 11075 SW 11th St, Beaverton, OR, 97005, US

PRODUCT FEATURES

Experience Color Like Never Before



This tri-color laser projector offers superior color range and uniformity thanks to its RGB lasers. This color range is supplemented by Dolby Vision, an HDR imaging technology that significantly boosts color, contrast, and brightness.



Impressive & Lifelike Detail

The Aurora Pro features 4K resolution to deliver sharper, lifelike images across a supersized screen.



A Whole New Realm of Audio & Visual

Enjoy an immersive cinematic experience with built-in 60W stereo speakers (two 15W woofers and two 15W tweeters) and 3D movie support. The Aurora Pro also features Dolby Atmos support for state-of-the-art surround sound.

For Rooms of Any Size

150"

A huge screen is possible of any size with the ultra-short throw lens on the Aurora Pro, which casts a projection of up to 150 inches when placed just over a foot away from the projection surface.

Fluid & Accurate Motion

MEMC

Enjoy ultra-smooth motion and reduced ghosting with responsive MEMC technology. This high refresh rate makes it easier to keep track of the action while watching sports or playing video games.

WHAT'S IN THE BOX?

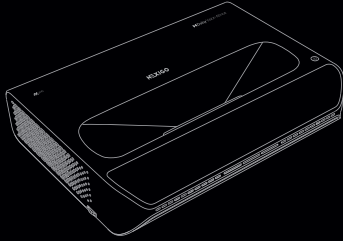

Projector x 1



AAA Batteries x 2



Power Cable x 1



Quick Start Guide x 1



User Manual x 1



Cleaning Cloth x 1



Remote x 1



Please note that the power cable included in the package may vary depending on your country.

PROJECTOR DIAGRAM

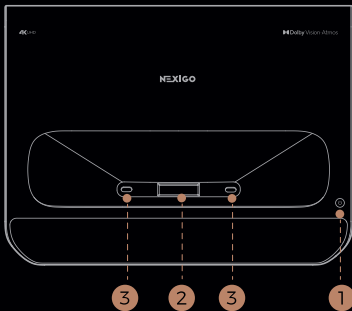

TOP VIEW

- ① Power Switch
- ② Lens
- ③ Eye Protection Sensors

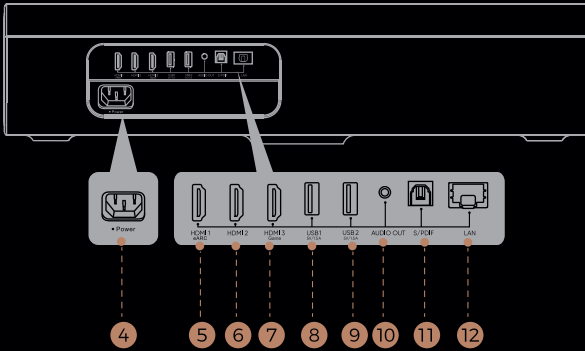

BACK VIEW

- ④ Power Input
- ⑤ HDMI 1(Support eARC)
- ⑥ HDMI 2
- ⑦ HDMI 3
- ⑧ USB 1 (5V ===1.5A)
- ⑨ USB 2 (5V ===1.5A)
- ⑩ Audio Out (3.5 mm Jack)
- ⑪ S/PDIF
- ⑫ LAN

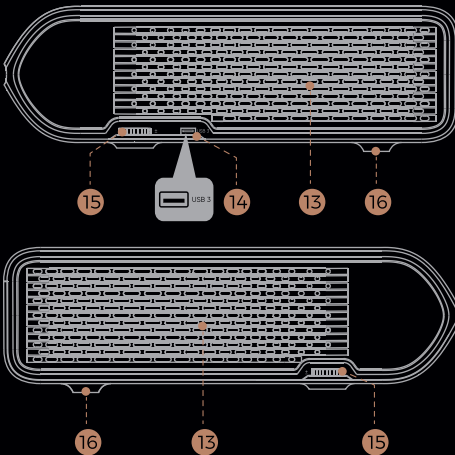

SIDE VIEW

- ⑬ Cooling Vents
- ⑭ USB 3 (5V ===1.5A)
- ⑮ Height Adjustment Wheels
- ⑯ Feet

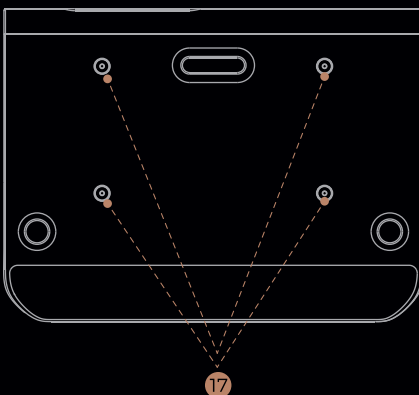

BOTTOM VIEW

- ⑰ M4 x 4 Screw Holes



Please use 4 x M4 screws with a length of 14mm when mounting the projector on the ceiling.

CONNECTORS AND PORTS

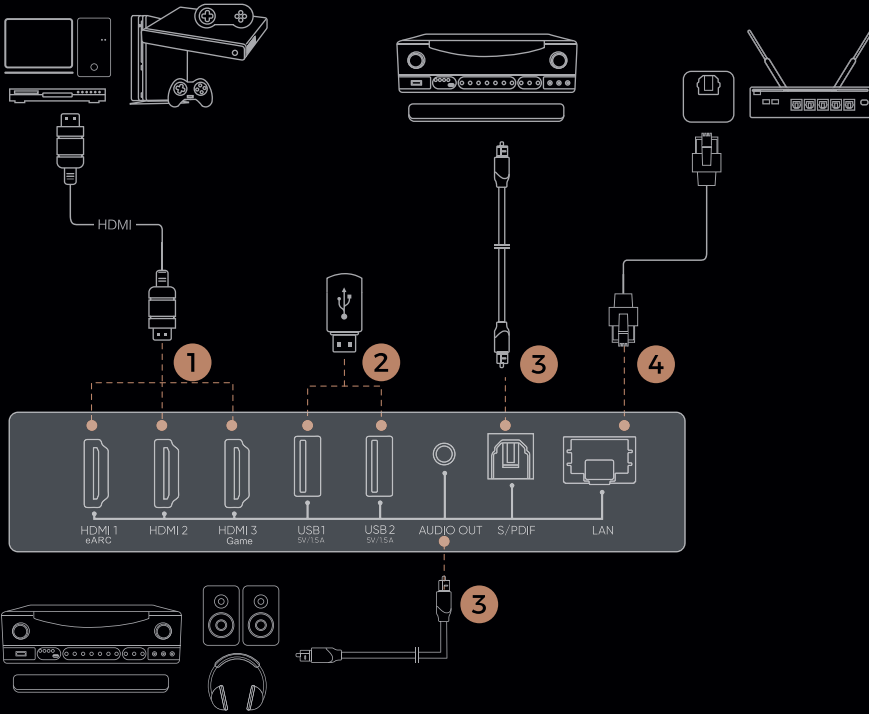

1: HDMI 1 (Support eARC) / HDMI 2 / HDMI 3

To connect items like: cable boxes, DVD players, digital media players (Roku, Fire TV, etc.), and computers.

2: USB 1 / USB 2 / USB 3

To connect items like mobile hard drives and USB flash drives.

3: Audio Out / S/PDIF

To connect audio devices like sound bar or speakers.

4: LAN

To connect an Ethernet cable.



When connecting a device to the projector, please be sure to:

1. Turn off all devices before making any connections.
2. Make sure the cable is inserted securely.
3. Use the appropriate cable for the device.

REMOTE INTRODUCTION

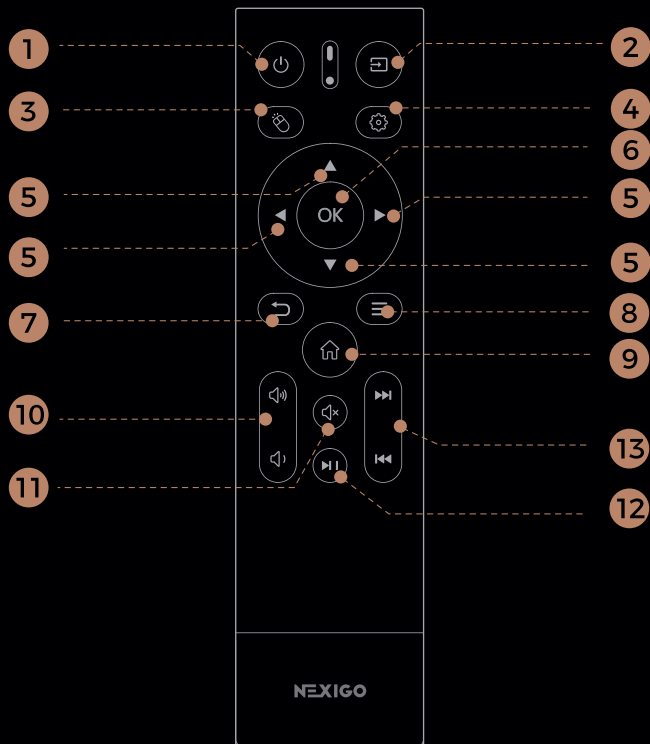

1. Power: Toggles power on and off.
2. Source: Adjusts the input source.
3. Air Mouse: Toggles motion control.
4. Settings: Opens the settings menu.
5. Left / Right / Up / Down: Moves the cursor within the on-screen display.
6. OK: Selects the highlighted option.
7. Return: Returns to the previous screen.
8. Menu (Press and hold): Opens the shortcut menu.
9. Home: Returns to the home page.
10. Volume + / -: Increases or decreases the volume.
11. Mute: Toggles audio on and off.
12. Play / Pause: Starts or stops a video.
13. Rewind / Fast Forward: Moves forward or backward within a video.

REMOTE CONTROL PAIRING

METHOD 1: INFRARED(IR) PAIRING

There are infrared (IR) sensors at the front center of the projector and on the remote. If you choose to use this method to control the projector, it has a maximum range of 26 feet.

METHOD 2: BLUETOOTH PAIRING

Confirm that the Bluetooth is turned on. Please ensure that you point the remote toward the projector and that the remote is within 7.87 inches of the projector. Press and hold the **Return** and **Menu** buttons simultaneously for at least 10 seconds to put the remote control into pairing mode with the projector. If the pairing is successful, the screen will show "The Remote is Connected".



- If the connection is disabled, you will need to re-pair the remote in order to continue using it via method 2.
- **Do not** place objects in front of the projector's IR sensor. This may prevent the sensor from operating properly.
- The IR sensor on the remote, like all IR sensors, can be interfered with by extremely bright light sources. If the remote is not working properly, make sure that there are no bright lights shining on them.

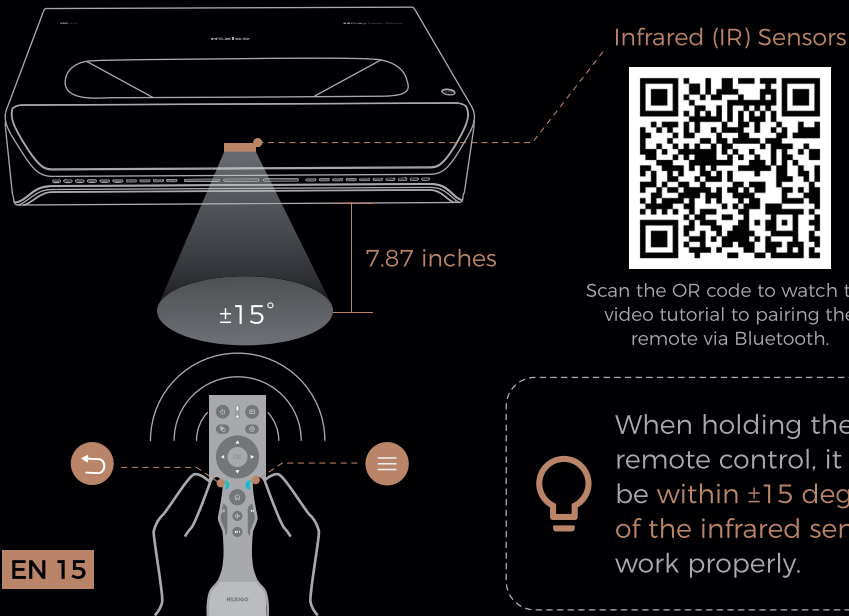

Infrared (IR) Sensors



Scan the QR code to watch the video tutorial to pairing the remote via Bluetooth.



When holding the remote control, it must be within ± 15 degrees of the infrared sensor to work properly.

SPECIFICATIONS

ITEM	TYPE	PARAMETERS
Basic Information	Model	PJ92
	Device Name	Aurora Pro
	Device Dimensions	547.1 x 122.2 x 407.5mm / 21.54 x 4.81 x 16.04 inches
	Product Weight	9.98 KG / 22lbs
Display	Resolution	3840 x 2160
	Refresh Rate	60Hz
	Throw Rate (TR)	0.233:1
	Projection Size	Up to 150"
Hardware	RAM	3GB
	ROM	128GB
	Wi-Fi	802.11ax 2.4G / 5G 2T2R WiFi 6
	Bluetooth	5.2
	Keystone Correction	Yes (Support 4 / 8-Point Keystone Correction)
Audio	Dolby Atmos	Yes
	DTS HD	Yes
	Speakers	2 x 15W Woofers, 2 x 15W Tweeters
Power	Power Consumption	300W (Normal)
	Input	100 - 240V~ @50 / 60Hz
	Standby Power Consumption	≤0.5W

ITEM	TYPE	PARAMETERS
Interfaces	HDMI	3 x HDMI 2.1
	USB	3 x USB-A 2.0
	Audio Out	1 x Audio Out
	S/PDIF	1 x S/PDIF
	LAN	1 x LAN
About	Storage Temperature	-4°F-131°F (-20°C-55°C)
	Working Temperature	32°F-104°F (0°C-40°C)
	Operating Humidity	30%~85%

INSTALLATION

While most projectors feature long-throw technology, the NexiGo Aurora Pro is an ultra short throw projector. Therefore, rather than placing it in the center of a room, you should position your device so it is directly in front of the screen. For a 120-inch projection, it should be approximately 0.96 feet away from the screen. Meanwhile, for an 80-inch projection, it should be approximately 0.33 feet away from the screen. Additional distance information is listed below in the [Projector Distance & Size](#) section of the manual (See [page 23](#) for details).

CHOOSING A LOCATION

The room layout and the design of the room will be the most important factors in choosing where to place the projector. Consider the following when selecting a location:

- The size, shape, and position of your screen.
- Location of a suitable power outlet.
- Ensure the projector has sufficient space around it for airflow.

The projector is designed to be installed in one of four layouts. You can either hang the projector from the ceiling via a special mounting bracket (NOT INCLUDED), or simply place it on a stable surface. You may need to change the projection mode so the images project correctly. Select **Projection Mode** under **Display Setting** tab, then choose the corresponding projection mode for your needs.

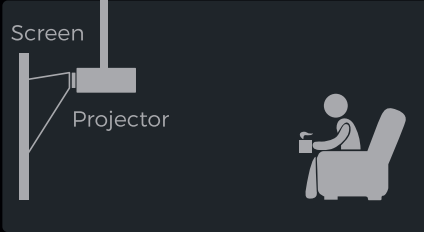

Ceiling mounted (front projection)

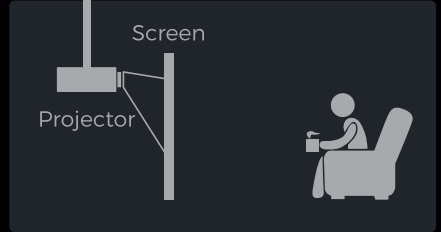

Ceiling mounted (rear projection)

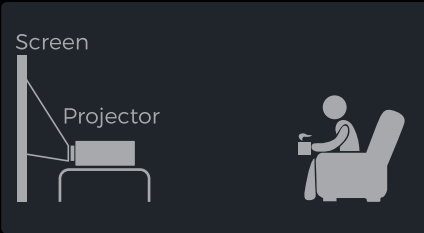

Desktop (front projection)

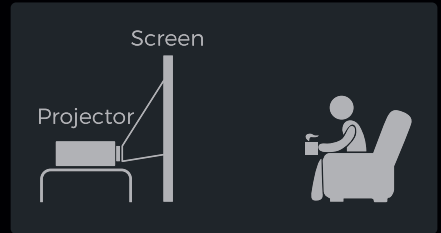

Desktop (rear projection)

- **For Rear Projection:** A specific rear projection screen is required to use the rear projection function.
- **For Ceiling Mounting:**



1. Please find the 4 x M4 screw holes on the bottom of the projector for mounting on the ceiling.
2. The projector's mounting holes are **M4 x 14mm** in size. The distance between these mounting holes on the back of the projector measures **13.1"** diagonally, **11.7"** horizontally, and **5.9"** vertically. You could find a suitable ceiling mount based on these specifications.

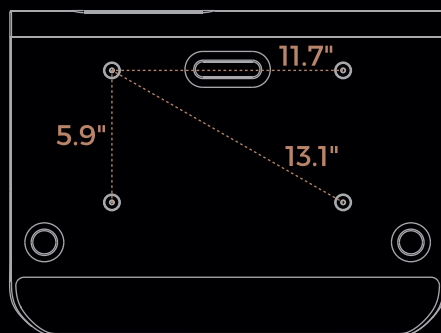

If the projector is resting on a table, you may need to adjust the height of the projector's feet. There are two feet for vertical height adjustment at the front of the unit and on the side. As shown in the figure below, turn the height adjustment wheel to adjust the feet.

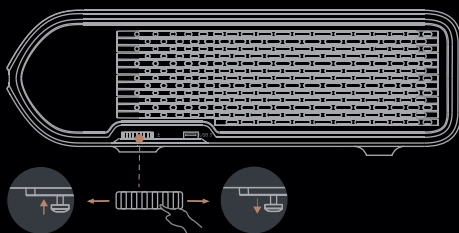

Turn the adjustment wheel forward to raise it.
Turn the adjustment wheel backward to lower it.

IMAGE ADJUSTMENT

ADJUST THE HEIGHT OF THE PROJECTOR'S FEET

Turn the adjustment wheel forward / backward to the appropriate height.

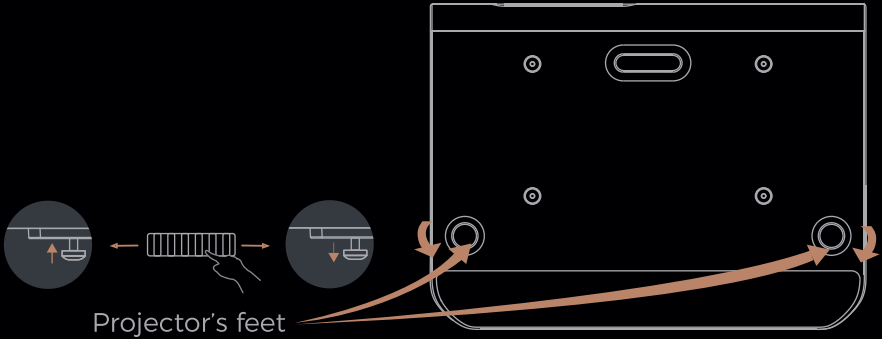

ADJUST THE IMAGE

Adjust the image to a rectangle that is smaller than the screen and parallel to the four sides of the screen.

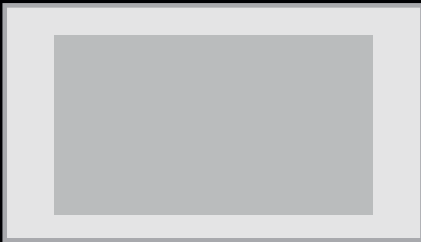

Then move the projector vertically and horizontally to adjust the projected image to the same size as the screen, to provide a perfect scaled image with uniform focus.

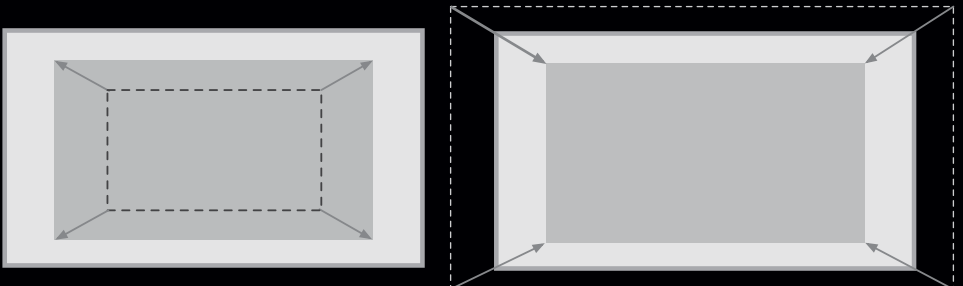

ADJUST THE ANGLE SLIGHTLY

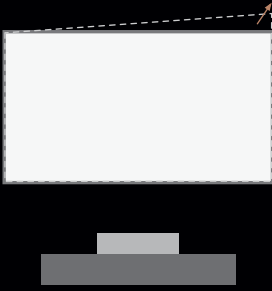

Problem / Issue:
The angle is at the upper right corner.

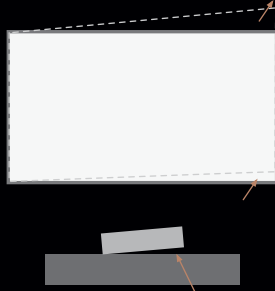

1. Raise the right foot of the projector.

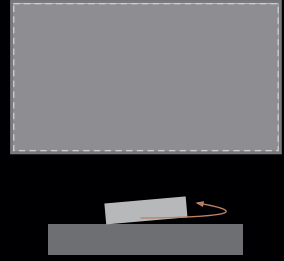

2. Rotate the projector counterclockwise.

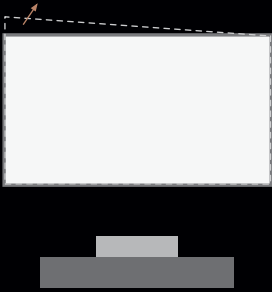

Problem / Issue:
The image is angled at the upper left corner.

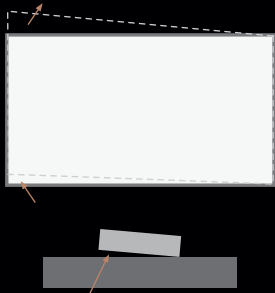

1. Raise the left side of the projector.

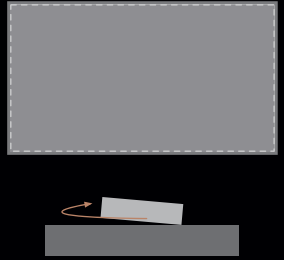

2. Rotate the projector clockwise.

KEYSTONE CORRECTION

If the projection shape is still not right after using the above methods, you can use the keystone correction function to adjust it. Press the **Menu** button on the remote control and navigate to **Display > Keystone Correction** to enter the correction mode.

Display

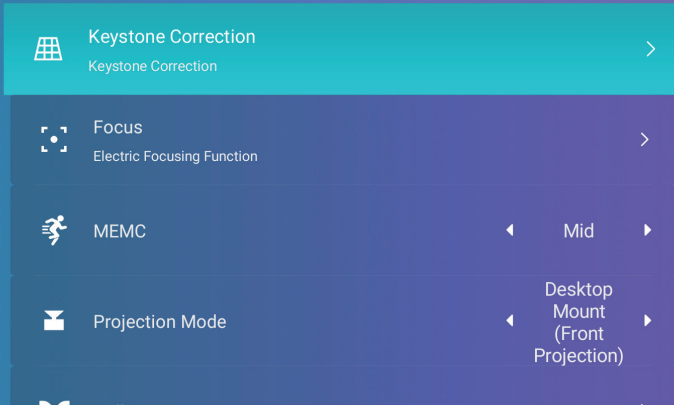

Choose the four-point or eight-point correction mode as shown below, depending on the level of adjustment needed. Select the point to be adjusted and press the **OK** button. After that, the direction symbol will appear. Adjust the shape of the projection using the direction keys until it appears correct, and press the **OK** button to save the adjustment.

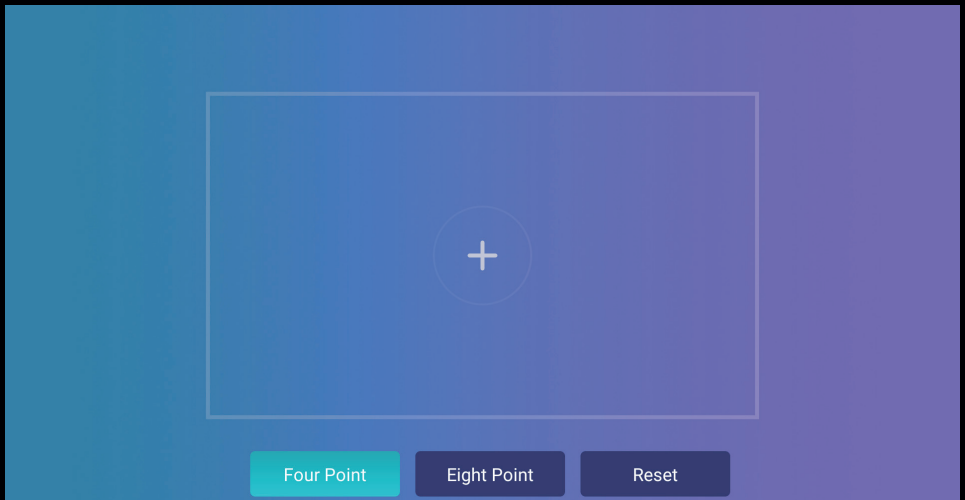

PROJECTOR DISTANCE & SIZE

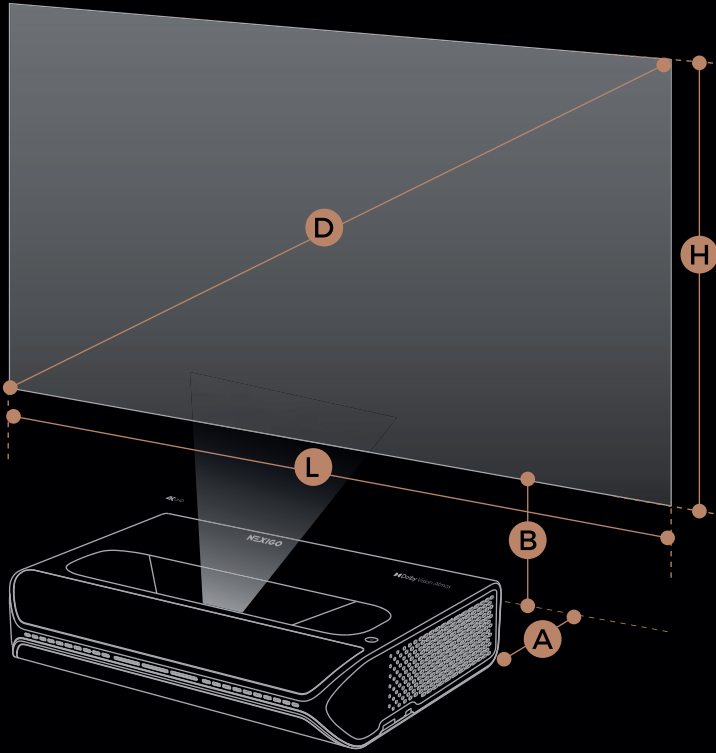

D Screen Diagonal	L Image Length	H Image High	A Projection Distance	B Screen to Desktop
80"	70"	39"	0.33ft	0.98ft
90"	78"	44"	0.49ft	1.06ft
100"	87"	49"	0.65ft	1.14ft
110"	96"	54"	0.81ft	1.22ft
120"	105"	59"	0.96ft	1.31ft
135"	117"	66"	1.20ft	1.43ft
150"	131"	74"	1.44ft	1.55ft



- The screen aspect ratio and the projected picture are both in a 16:9 aspect ratio.
- Due to manufacturing tolerances, there will be variances of about 3% from unit to unit. As such, the data shown above is for general reference only. Please test your measurements before installing the device.

QUICK START GUIDE

STEP 1 - PLUG THE UNIT IN

Plug the projector into a power outlet using the provided power cord.

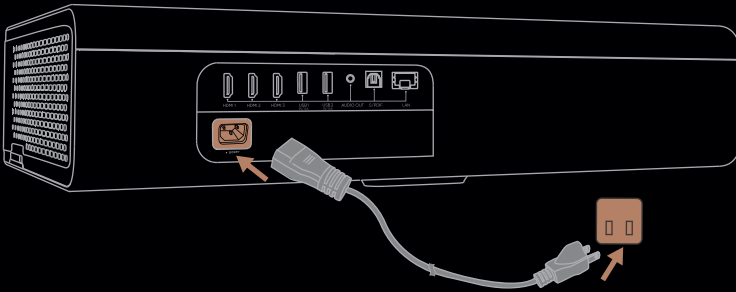

Power Button / Power Indicator:

Press the Power button on the projector to turn on the projector. The power indicator will flash during the device startup process.

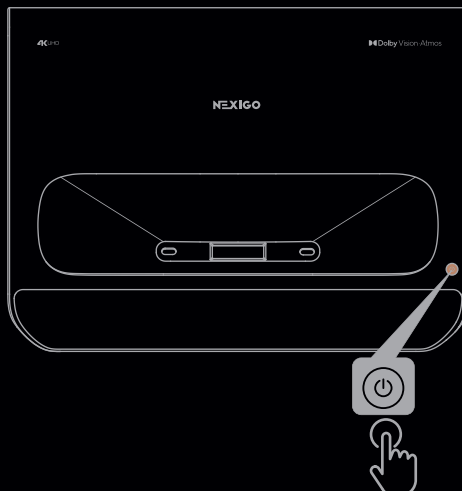

STEP 2 - INSTALL THE BATTERIES

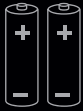

1: Locate the included batteries.



2: Slide the battery cover off.

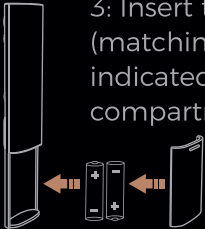

3: Insert the batteries (matching + / - polarity as indicated) into the battery compartment.



4: Slide the battery cover back into position.



- Ensure that the batteries are installed properly. If the battery compartment has a protective film, please remove it.
- Avoid exposing the remote control and its batteries to excessive heat or humidity, such as in the kitchen, bathroom, sauna, sunroom or a closed car.
- Replace the batteries with only the same or equivalent type recommended by the battery manufacturer.
- Dispose of used batteries according to the local environmental regulations for your region.
- Never dispose of batteries in a fire, as there is a risk of explosion.
- If the battery is dead or the remote control will not be used for a long time, please remove the battery to avoid battery leakage and damage to the remote control.

STEP 3 - PAIR THE REMOTE WITH THE PROJECTOR

Press and hold the **Return** and **Menu** buttons on the remote at the same time for three seconds. The remote control and the device will enter pairing mode. If the pairing is successful the screen will display "The Remote is Connected".

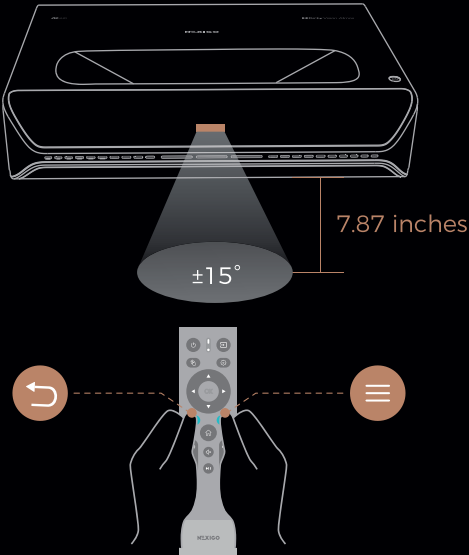

When holding the remote control, it must be within ± 15 degrees of the infrared sensor to work properly.

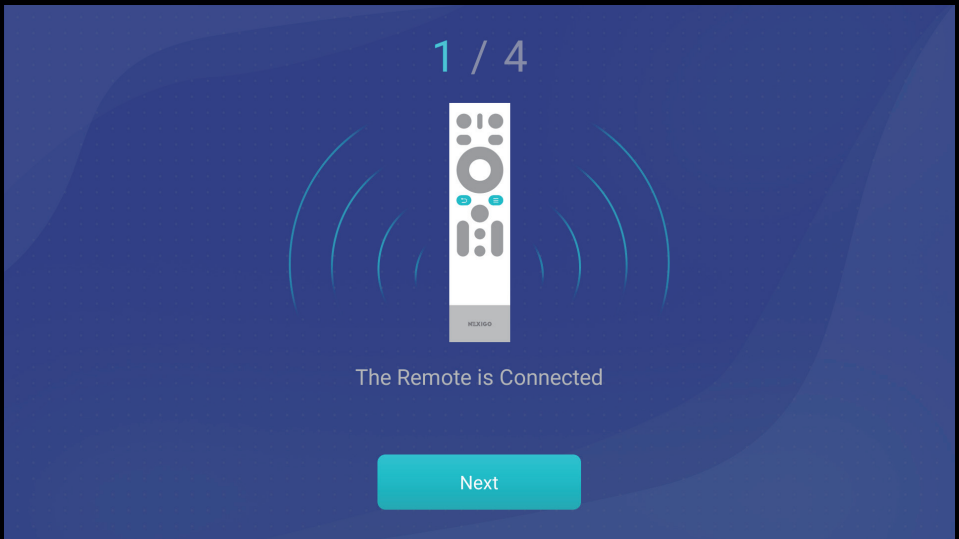

STEP 4 - SELECT YOUR PREFERRED LANGUAGE

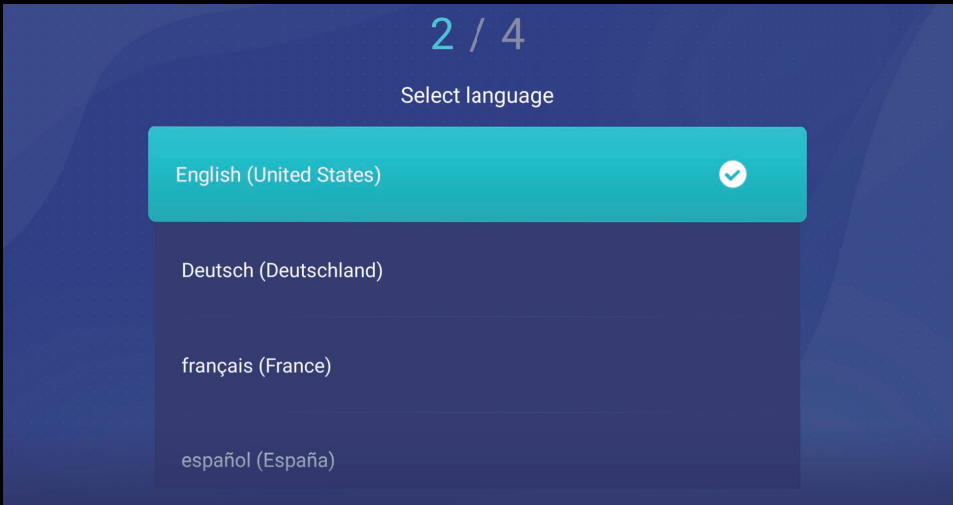

STEP 5 - CONNECT TO A NETWORK

Connect to the Internet via Wi-Fi or Ethernet cable. See details below in the settings section on the [page 31](#).

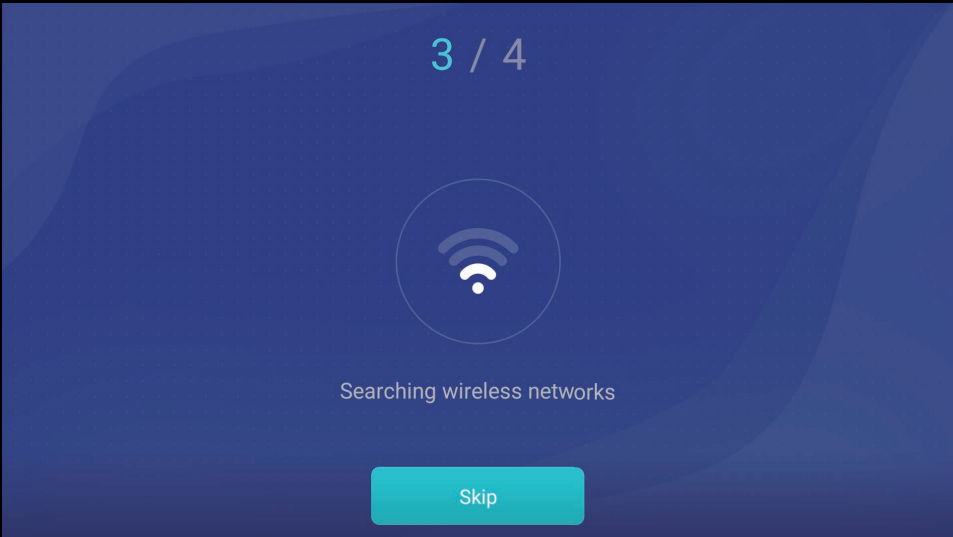

STEP 6 - CHOOSE YOUR PREFERRED INSTALLATION METHOD

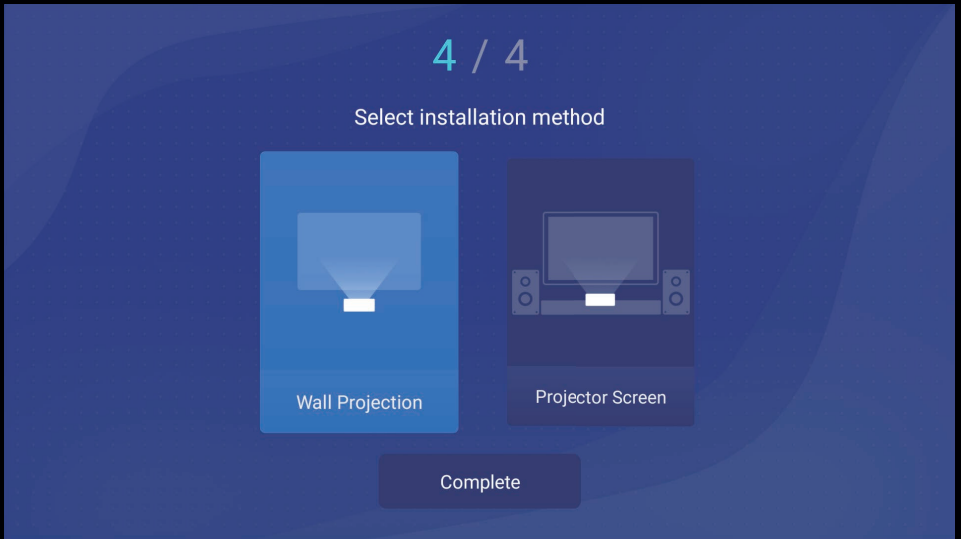

SHUTTING DOWN THE PROJECTOR

Press the **Power** button on the remote or device and select **Power Off** to turn off the projector. It is recommended to unplug the power if the projector is not in use for an extended period.

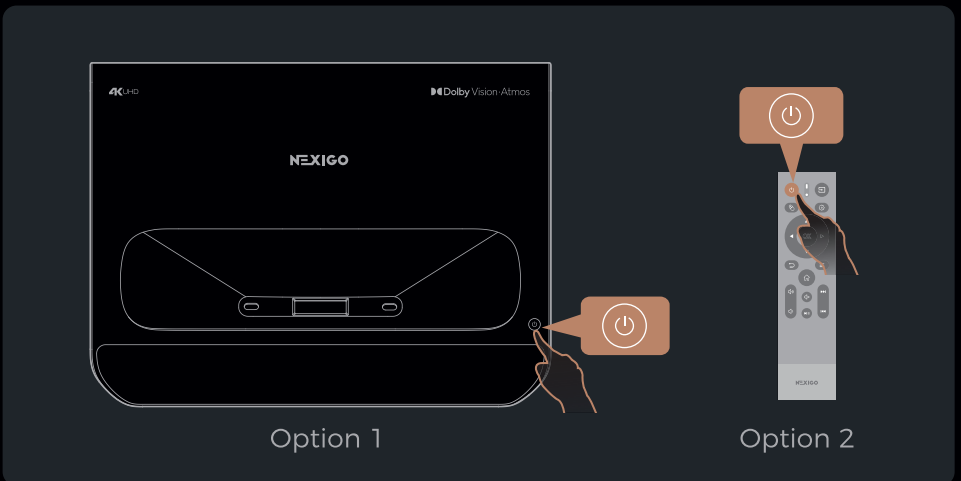

FILE MANAGER

You must insert a USB drive into the projector before you open the file manager to see its contents. In the file manager, you will find files in the internal storage and / or the USB drive. You can also check files shared by other devices on the same network using the **Network** option.

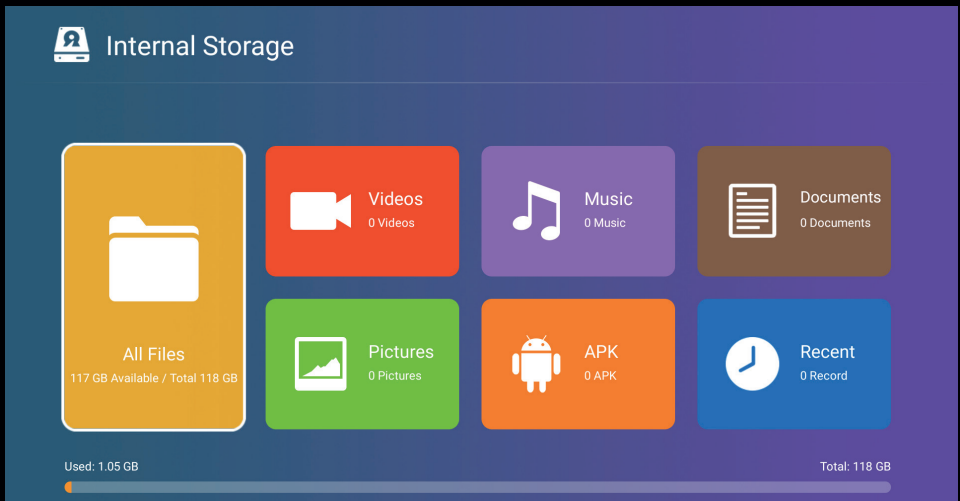
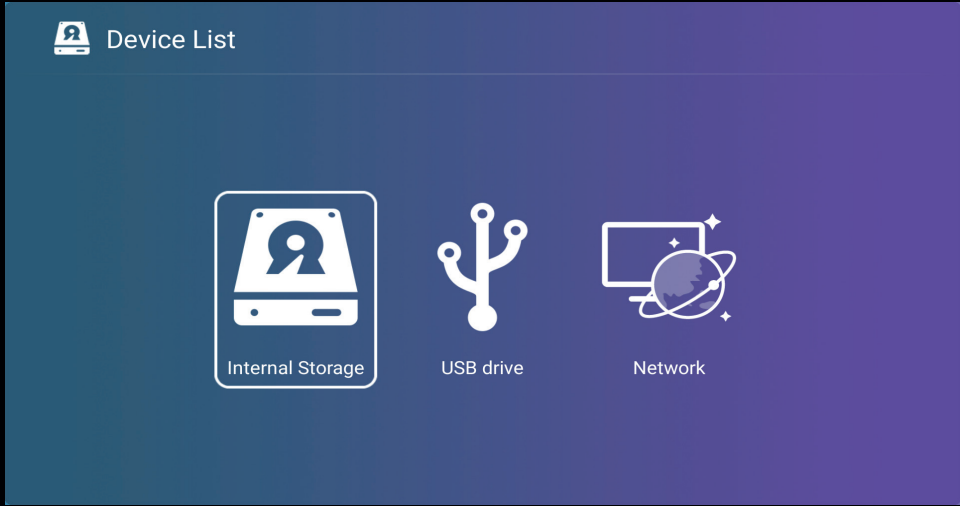

The supported file formats are shown in the table below.

Settings	Options	Supported Format
USB File Management	Video	MP4 / MPEG / VOB / MKV / TS / AVI / FLV / 3GPP / RMVB
	Audio	MP3 / AC3 / FLAC / WAV / M4A
	Document	.doc / .docx / .txt / .pdf
	Photo	JPG / JPEG / PNG / BMP / TIF
	3D Video	Top-Bottom / Side By Side (Play a 3D video from applications or a USB flash drive) Frame Sequential / Frame Packing / Top-Bottom / Side By Side (Play a video from your HDMI source)

3D SUPPORT TIMING

3D Format	Signal	Resolution	Aspect Ratio	Refresh Rate(Hz)
Frame Packing	720p	1280 x 720	16:9	24 / 30 / 50 / 60
	1080p	1920 x 1080	16:9	24 / 25 / 30 / 50 / 60
	4K	3840 x 2160	16:9	24 / 25 / 30
Side By Side	720p	1280 x 720	16:9	24 / 30 / 50 / 60
	1080p	1920 x 1080	16:9	24 / 30 / 50 / 60
	4K	3840 x 2160	16:9	24 / 25 / 30
Top-Bottom	720p	1280 x 720	16:9	24 / 30 / 50 / 60
	1080p	1920 x 1080	16:9	24 / 30 / 50 / 60
	4K	3840 x 2160	16:9	24 / 25 / 30

SYSTEM SETTINGS



The UI interface is for reference and may change with system upgrades.

Under the **Settings** menu, you will find the options shown below:

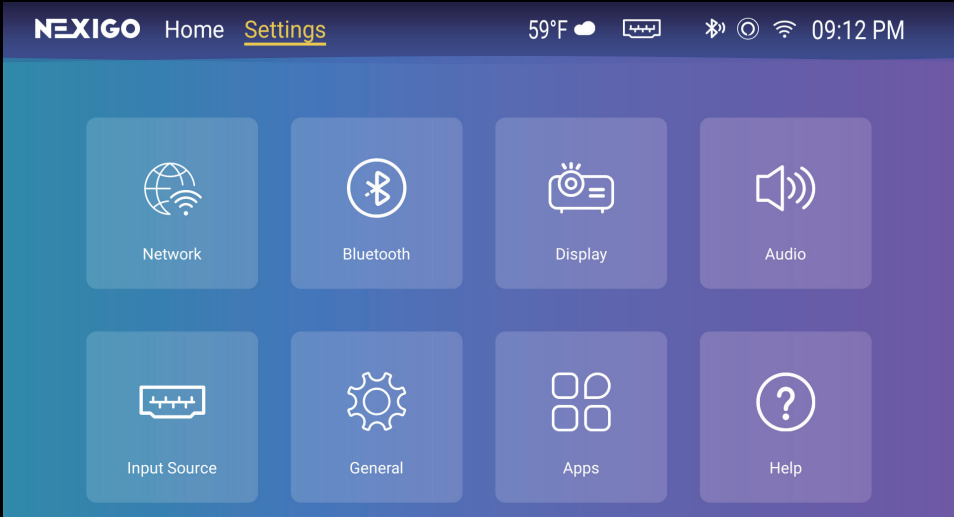

BLUETOOTH CONNECTIONS

To connect your projector to a Bluetooth device, you must first turn on Bluetooth connections for the projector and any device you wish to pair it with.

Pairing with Audio Devices -

The projector can be connected to a Bluetooth audio device. Please choose **Output for Audio Mode** in the menu, then scroll down to **Search Device** until you see the Bluetooth audio device you wish to connect to.

Bluetooth Settings

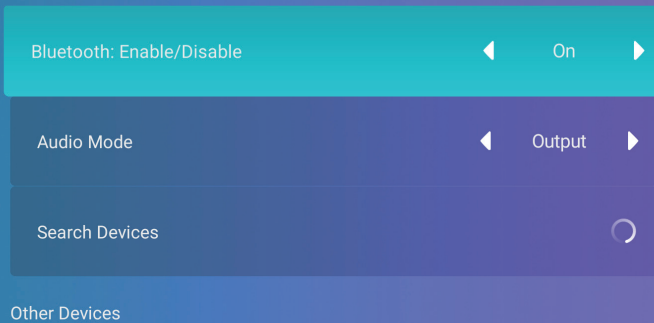

Use the Aurora Pro as a Bluetooth Speaker -

You can play audio from another source on the built-in speaker of the projector using Bluetooth connection. Choose **Input** under Audio Mode in the menu, then turn on wireless connection on the device you would like to connect. Search on the external device and connect to the Aurora Pro.

Bluetooth Settings

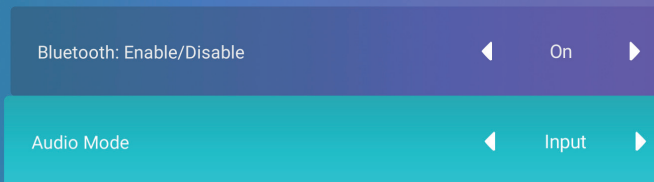

DISPLAY

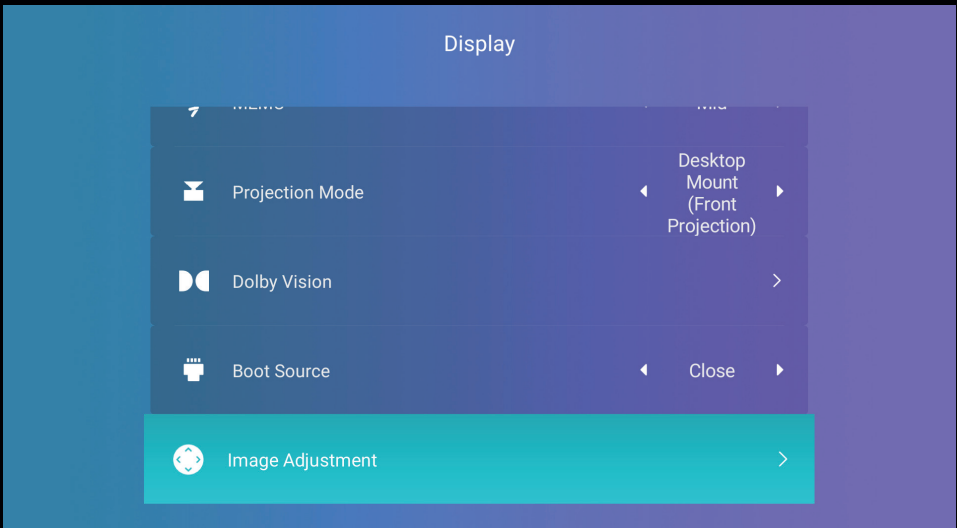
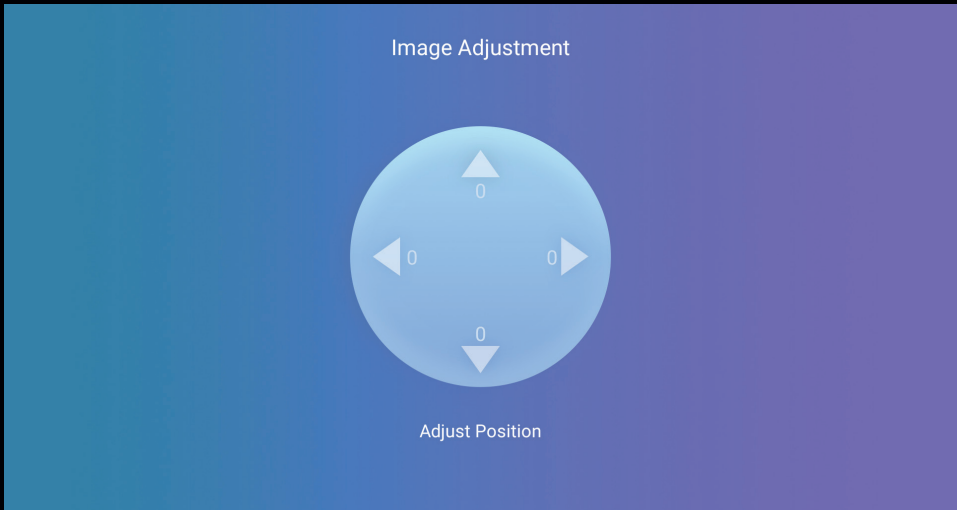

Image Adjustment -

Adjust the image without moving the projector. You can adjust the zoom or the position of the image using the arrow keys on the remote.



Brightness Mode -

Set the projector brightness to either Standard or Brightest depending on your needs.

Image Parameters -

Adjust the image, mode, brightness, contrast, saturation, sharpness, hue, and color temperature.

MEMC -

Watch your favorite movies with the responsive Motion Estimation, Motion Compensation (MEMC) feature. The options are off, high, low, and mid.

Keystone Correction -

Choose the four-point or eight-point correction mode depending on the level of adjustment needed. Select the point to be adjusted and press the OK button. After that, the direction symbol will appear. Adjust the shape of the projection using the direction keys until it appears correct.

Focus -

Press the left arrow button or right arrow button on the remote to adjust the focus.

Projection Mode -

Changes the display mode of the projector. The options are Normal, Mirror, Flip, and Mirror Flip.

Boot Source -

This selects the default source to open when the projector is powered on. The options are Close, HDMI 1, HDMI 2 and HDMI 3.

INPUT SOURCE

In the Input Source settings menu you can choose the signal source for the connected device you wish to display on the projector.

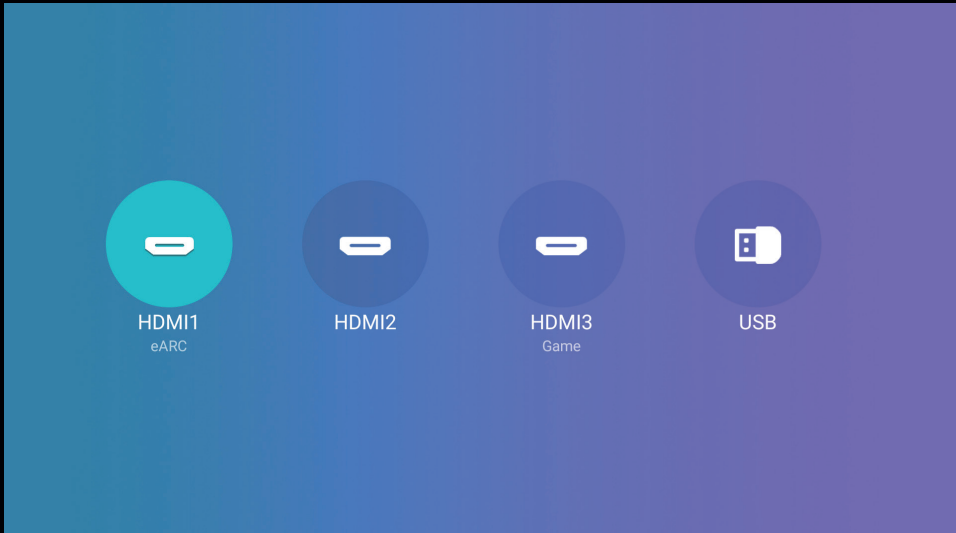

HDMI Video Timing

Signal	Resolution	Aspect Ratio	Refresh Rate(Hz)
480i	720 x 480	4:3 / 16:9	60 / 120
480p	720 x 480	4:3 / 16:9	60 / 120
576i	720 x 576	4:3 / 16:9	50 / 100
576p	720 x 576	4:3 / 16:9	50 / 100
720p	1280 x 720	16:9	24 / 25 / 30 / 50 / 60 / 100 / 120
1080i	1920 x 1080	16:9	24 / 30 / 60 / 120
1080p	1920 x 1080	16:9	24 / 25 / 30 / 50 / 60 / 120 / 240
4K	3840 x 2160	16:9	24 / 25 / 30 / 50 / 60 / 120

HDMI PC Timing

Signal	Resolution	Refresh Rate(Hz)
VGA	640 x 480	60 / 72 / 75 / 85
SVGA	800 x 600	56 / 60 / 72 / 75 / 85 / 120
XGA	1024 x 768	60 / 70 / 75 / 85 / 120
WXGA	1280 x 720	24 / 25 / 30 / 50 / 60 / 100 / 120
	1280 x 768	60 / 75 / 85 / 120
	1280 x 800	60 / 75 / 85 / 120
Quad-VGA	1366 x 768	60
	1280 x 960	60 / 85 / 120
SXGA	1280 x 1024	60 / 75 / 85 / 120
SXGA+	1400 x 1050	60 / 75 / 85 / 120
WXGA+	1440 x 900	60 / 75 / 85 / 120
UXGA	1600 x 1200	60 / 65 / 70 / 75 / 85 / 120
WSXGA+	1680 x 1050	60 / 75 / 85 / 120
WUXGA	1920 x 1200	60 / 75 / 85
HDTV	1920 x 1080	24 / 25 / 30 / 50 / 60 / 100 / 120 / 240
4K UHD	3840 x 2160	24 / 25 / 30 / 50 / 60 / 100 / 120
DCI 4K	4096 x 2160	24 / 25 / 30 / 50 / 60 / 100 / 120

NETWORK

In the Network Settings menu, you can connect to the internet via a wired or wireless connection. For a wired connection, plug in the Ethernet cable to connect. For a wireless connection, please connect the projector to your local network.

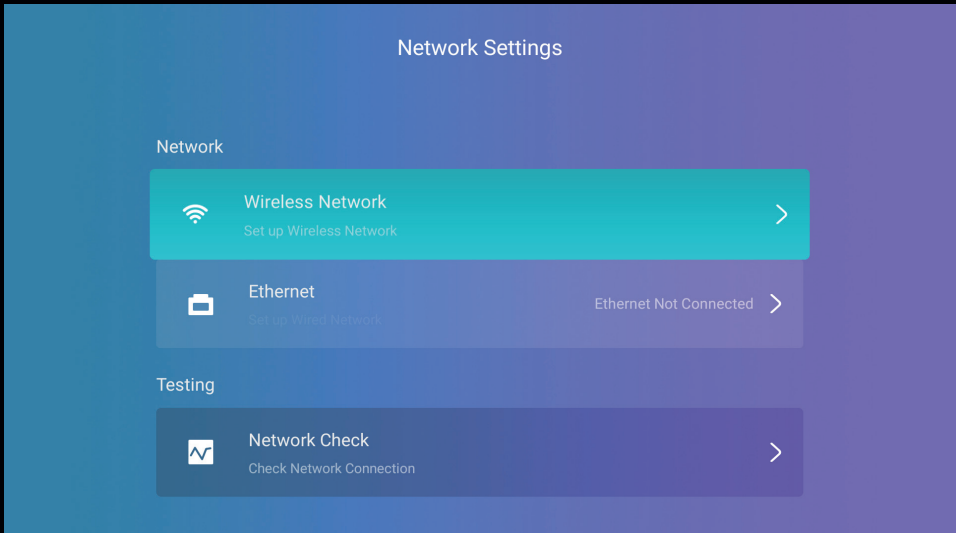

GENERAL

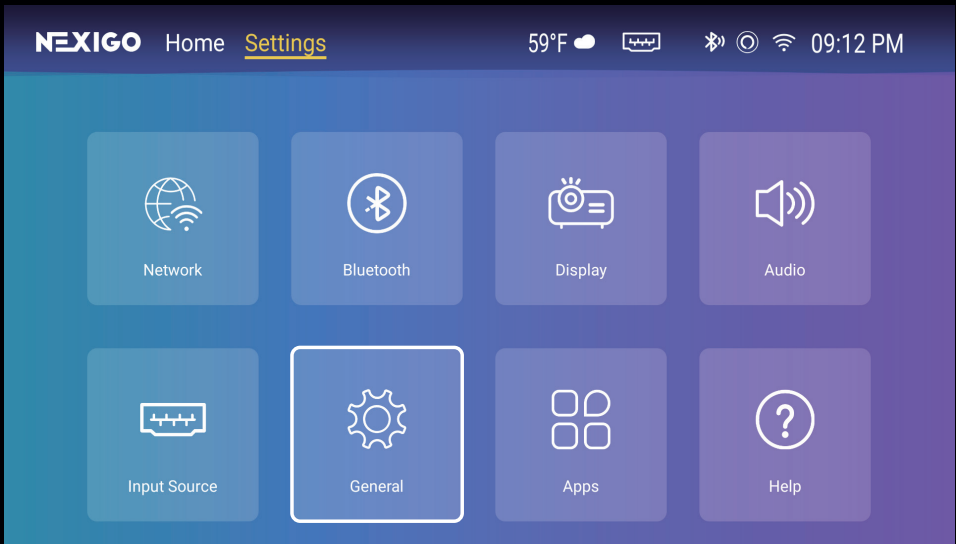

System Update Notifications -

Toggle system update notifications on and off.

System Version -

View the projector's current system version and update it to the latest version if necessary.

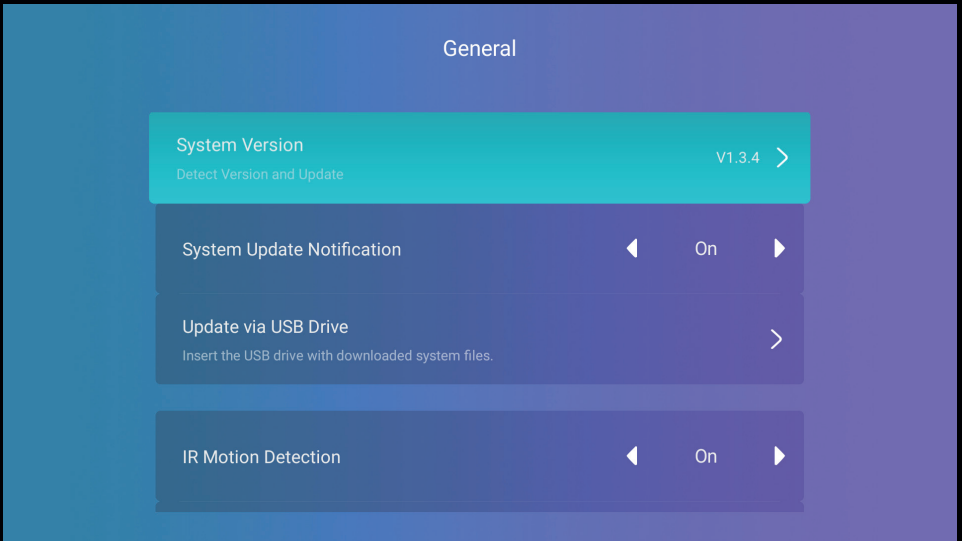

The first time you connect to the Internet, a prompt will appear asking whether you want to update the system. You can either choose yes or no. If you choose yes, the system will begin the update process. If you choose no, the prompt will disappear. You can go into system settings at any time to check the system version and update.

Update by USB Drive -

Insert a USB drive that has the appropriate system update files into the projector, select Update by USB Drive in the menu shown below, then follow the system prompts to update the projector's system firmware.

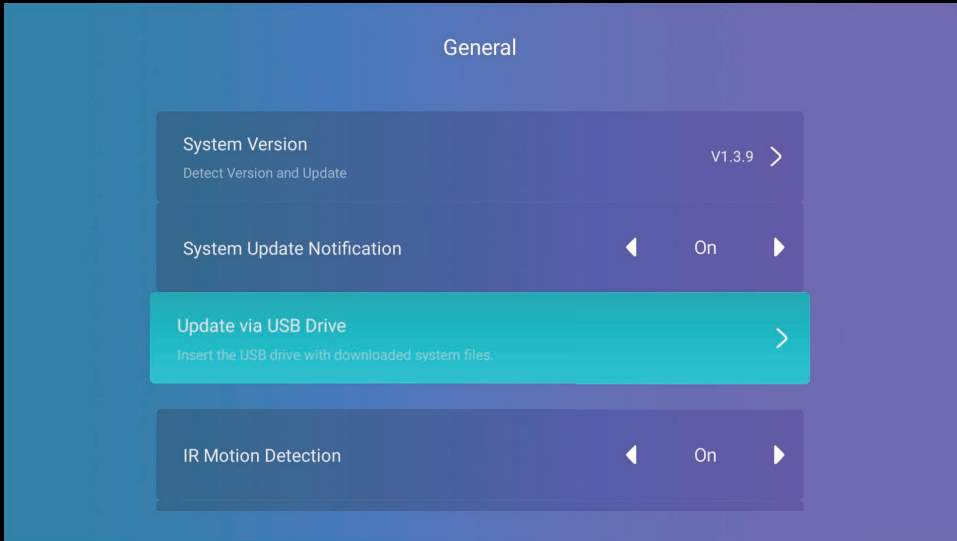

- Please insert the USB drive before selecting Update by USB Drive in the menu.
- Please copy all system update zipfile directly onto the root directory of the USB drive. Do not place it in a subfolder on the USB drive or it will not be able to find the files.

Device Name -

Show the projector's name.

IR Motion Detection -

There are two PIR motion sensors at the front of the projector. When it detects people approaching, the projector will turn off the laser light to protect their eyes. This function is active by default and can be disabled in the Settings menu under General. If the projector turns off due to motion detection, you may press any button on the remote control and the laser light will return to its normal brightness.

Sleep -

Set a timer for the projector to enter Sleep Mode. When the projector enters Sleep Mode the projector display will turn off.

Time Format -

This setting allows you to set different time formats. Choose from either a 12-hour or 24-hour cycle.

Time Zone Selection -

You can select the appropriate Time Zone for your region.

Language Settings -

Select your preferred display language.

Unknown Sources -

Unknown sources is an Android accessibility setting that allows the projector to trust and install applications from developers, publishers, or other sources outside of the Google Play store. You can turn this function on or off as needed.

About -

View the projector's technical information such as the product serial number, software version information, network information, disk information, and legal information.

Factory Reset -

Reset the device to factory settings.

APPS

Install Apps -

You can install apps onto the projector by downloading APK files from trusted third parties.

- Download an APK file from a trusted website and copy it onto a USB drive (FAT32 format).
- Enable installation from unknown sources by going to **Settings > General > Unknown Sources > On**.
- Plug the USB drive into the Aurora Pro.
- Go to **Input Source > USB > USB Drive > APK** to open the file and select **Install**.

Uninstall Apps -

- Go to **Settings > Apps** and hover over the app you want to uninstall.
- Press the **Menu** button on the remote.
- Select **Uninstall** and confirm your choice to uninstall the app.

AUDIO

Touch Tones -

Toggle navigation sounds on or off.

Audio Mode -

Set the Audio Mode to either Music or Movies.

Dolby Audio -

Turn the Dolby Audio on or off.

Audio Output -

Set this to: Speaker, S/PDIF, Headphones, or HDMI ARC.

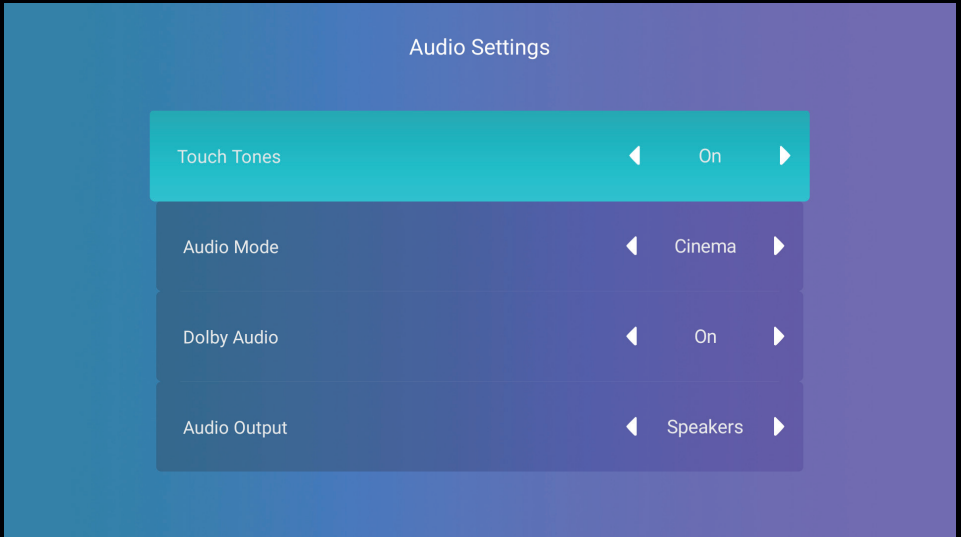

MULTISCREEN CONNECTIONS

You can wirelessly connect your iPhone, iPad, MacBook, computer, or a wide range of other devices to the projector. Alternatively, you can use a wired connection with your iPhone or iPad to share your screen.

For a wireless connection, ensure the projector and your device are connected to the same network. Instructions on how to connect the projector to a network are available in the network section of the manual.

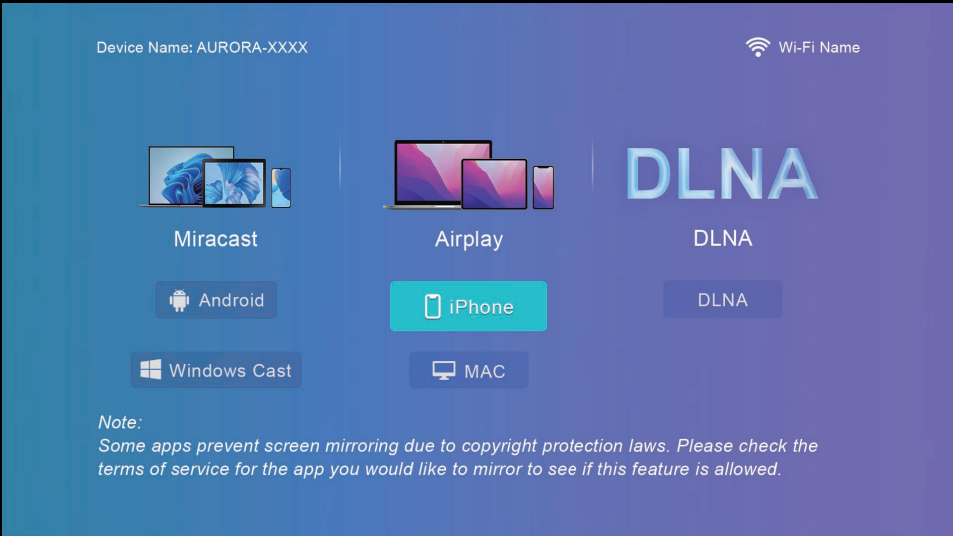

Miracast -

Shares the screen from an Android phone or tablet wirelessly. To connect, make sure both devices are connected to the same Wi-Fi network. Open **System Settings** on your Android device and search for its casting software. Once you have opened the casting software, go to the list of available mirroring devices and select "**Aurora Pro XXXX**".

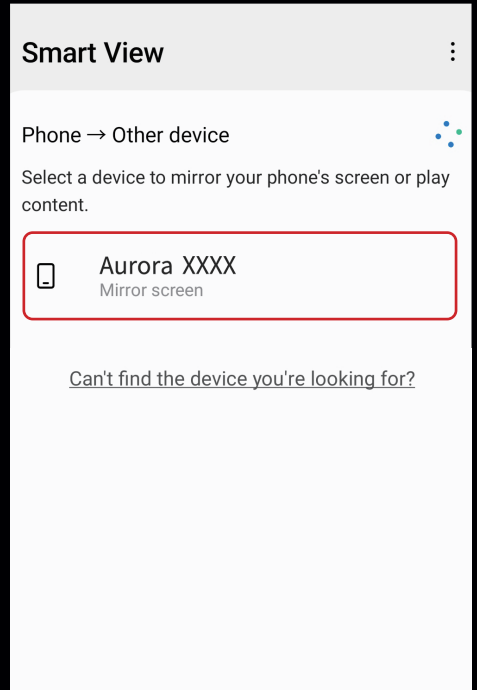
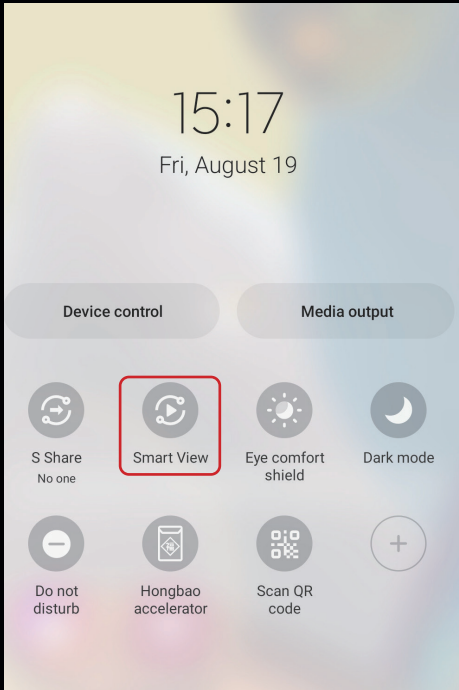

- Android devices may have mixed functionality with Miracast. Most devices have a built-in app that supports it. (OnePlus / Google Pixel - Search Cast, Samsung - Search Smart View, Sony - Search Screen Mirroring.) Please refer to the instructions of your device for details.
- Additionally, there may be third-party apps you can download to your Android device to provide Miracast functionality. We cannot guarantee that this will work as intended with all Android devices. Check your device manufacturer for information regarding support for this standard.

DLNA -

Share the display from another device that supports DLNA connections.



To connect via DLNA, first ensure that both devices are connected to the same network.

On the device that you want to cast from, open a video or other file you want to share that supports DLNA (YouTube for instance), and then tap the button on the app that allows you to cast. Next, select "Aurora Pro XXXX" from the list of options. Finally, press the play button on the video and it will now show the video on the projector.

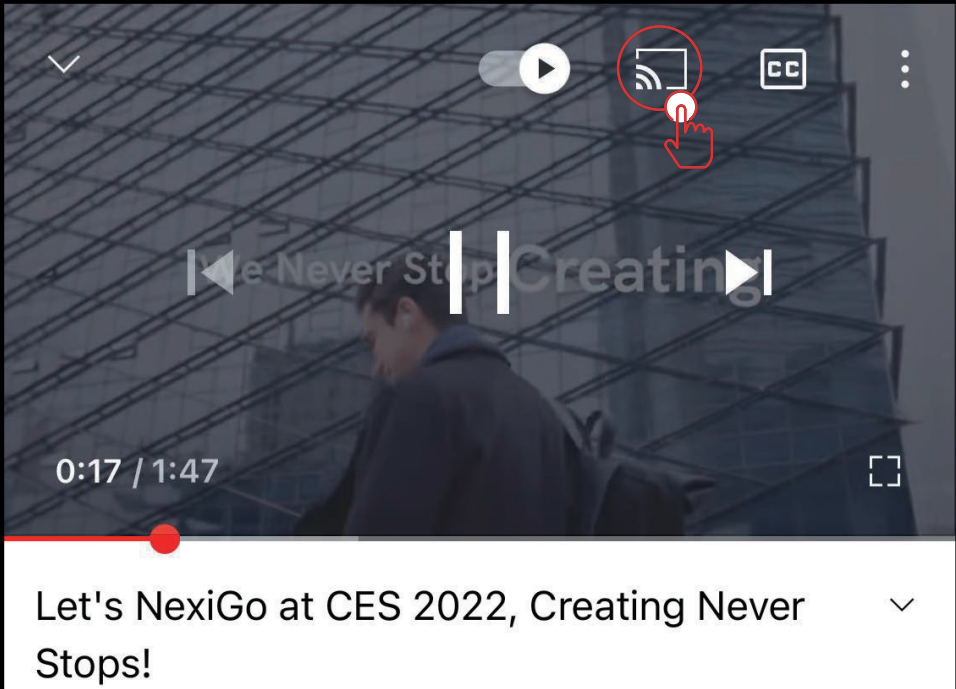

AirPlay Instructions -

AirPlay is an application designed to share content between Apple iOS devices and macOS devices, as well as with specialized third-party pieces of hardware. To set up this connection, we need to:

1. Make sure that your iOS device is connected to the same Wi-Fi network as the Aurora Pro.
2. Go to your iOS device's **System Settings** and enable the AirPlay function. Then, select "Aurora Pro XXXX" to establish the connection from the list of available devices.
3. Your device is now connected.

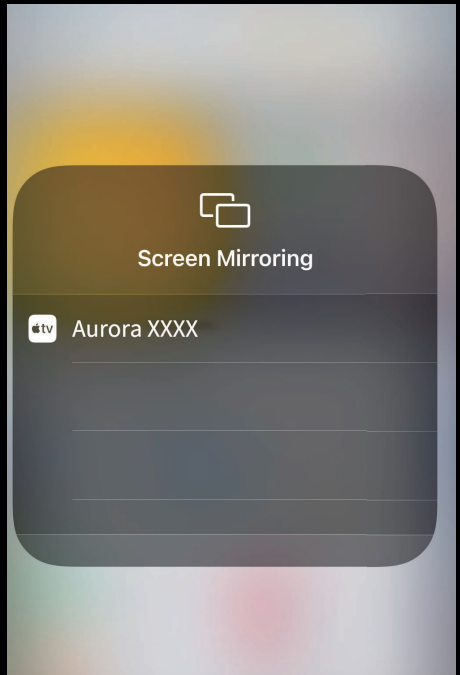
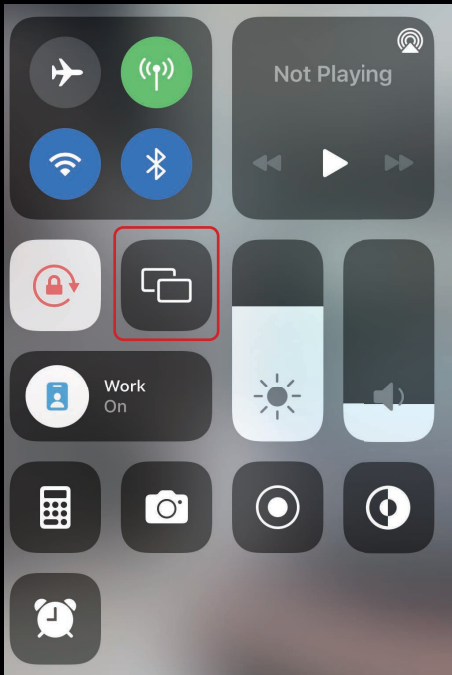

AMAZON ALEXA VOICE CONTROL SETUP

Step 1: Connect to your home Wi-Fi network.

Ensure that you have the Amazon Alexa app set up on your phone or tablet and that your mobile device is connected to the same Wi-Fi network as the Aurora Pro.

Step 2: Enable the Whale Video skill on your Alexa app.

On the Alexa app on your phone, navigate to More > Skills & Games and then type "Whale Video" into the search bar.

Open the Whale Video Smart Home skill. This skill enables voice control on devices with access to Alexa. Select **Enable to Use** to add Whale Video to your Alexa account.

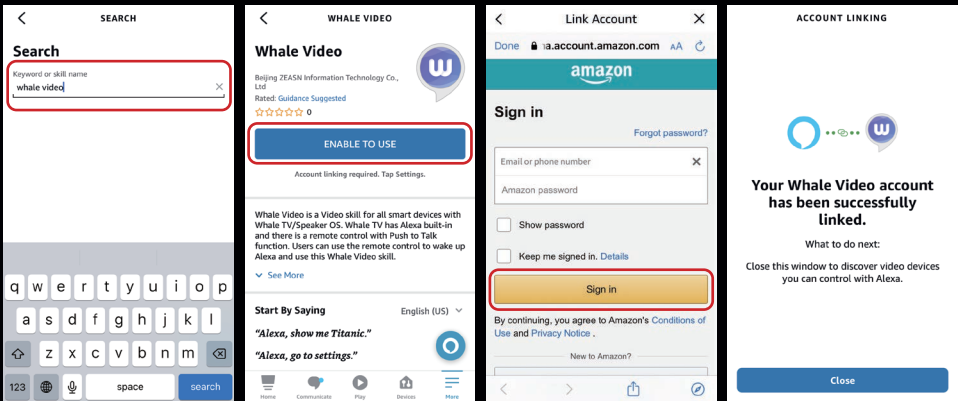

At this point in the process, you may be prompted to sign in again to your Amazon account before you can continue. To finish linking your accounts, you will also need to grant permission for Whale Video to access your profile.

Step 3: Link your projector and your Amazon account.

Return to your projector. Select the speech bubble icon in the top right-hand corner of the screen and enter your login info to begin linking your Amazon account to the Aurora Pro.

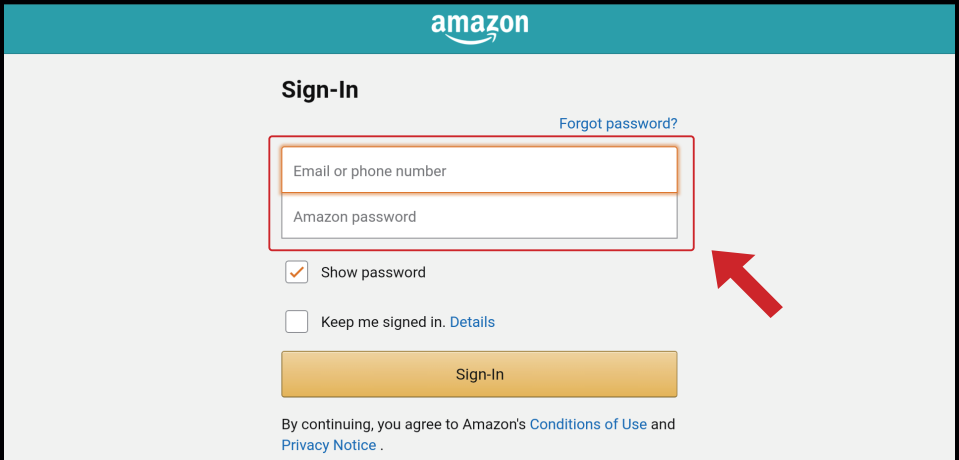

On your phone or tablet, open the Alexa app and navigate to **Devices**. If the Aurora Pro is not already present on your devices list, proceed to **Add Device > TV > Other > Wi-Fi**. Then select **Discover Devices > Set Up Device**.

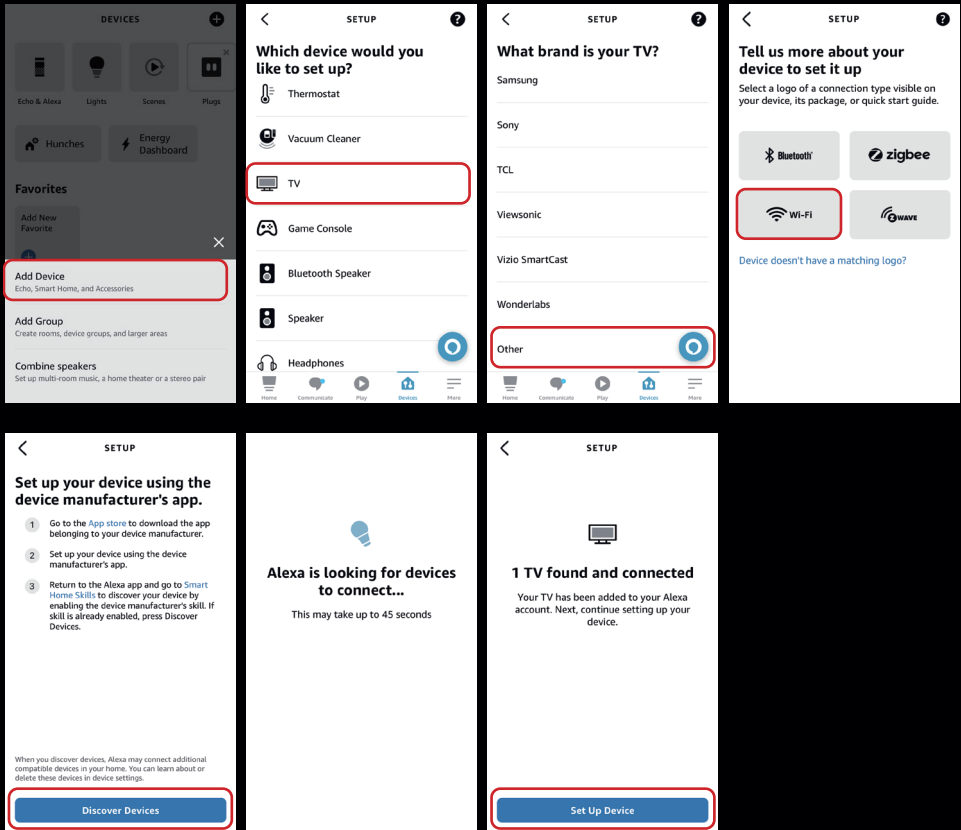

Step 4: Enable Whale Video to act as a remote control for your Aurora Pro. Now that your projector is linked to your Amazon account, return to the Alexa app on your phone and enable Whale Video to control the Aurora Pro in the settings. To do this, navigate to **More > Skills & Games > Your Skills** and select Whale Video from the list. Then tap **Settings > Manage In TV & Video** and choose Aurora Pro from the list of devices.

Select the Alexa device that you want to use to control the Aurora Pro, then choose **Link Devices**. Your Alexa voice control setup should now be complete.

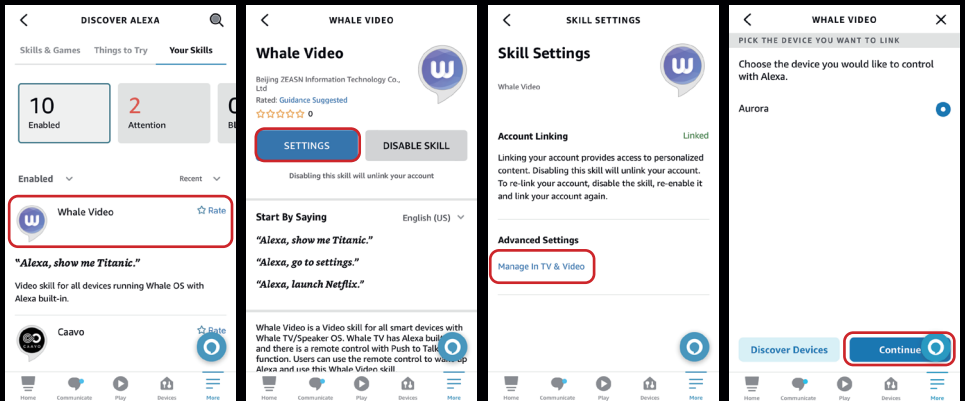

The setup for Alexa voice control may be slightly different depending on your device. If these steps do not line up with your interface and you're still having trouble connecting to the projector, please contact NexiGo customer service at cs@nexigo.com for assistance.

Step 5: Using Alexa

You can now control your projector with Alexa. For example, you can say: "Alexa, go to settings on Aurora Pro".

The additional voice commands for Alexa are shown below.

VOICE COMMANDS FOR ALEXA

1. Alexa, turn off Aurora Pro
2. Alexa, mute on Aurora Pro
3. Alexa, unmute on Aurora Pro
4. Alexa, go home on Aurora Pro
5. Alexa, go to settings on Aurora Pro
6. Alexa, set volume to [1 through 100] on Aurora Pro (1 being the softest and 100 being the loudest.)
7. Alexa, go to inputs on Aurora Pro
8. Alexa, jump to HDMI [1/2/3] on Aurora Pro

TROUBLESHOOTING

HOW DO I CONNECT MY SOUNDBAR TO THE PROJECTOR VIA HDMI?

Connect your soundbar to the HDMI 1 port (which supports eARC) on the projector using an HDMI cable. Then, navigate to **Settings > Audio > Audio Output** and select eARC as the audio output option. This ensures that audio is sent from the projector to the soundbar via HDMI with enhanced capabilities.

WHY IS THERE NO SOUND FROM AURORA PRO?

If there is no sound from Aurora Pro, you may have selected a different audio output source. Press and hold the Menu button to pull up the sidebar menu, select the speakers option from **Audio > Audio Output**. You can also go to **Settings > Audio > Audio Output** and select the speakers option.

HOW DO I ENABLE MOTION CONTROL ON THE AURORA PRO REMOTE?

Press the Air Mouse button on the remote and a cursor will appear on the screen. You should now be able to point the remote at the screen to direct the cursor.

CAN I ZOOM IN OR OUT WITHOUT MOVING THE PROJECTOR?

Yes, you can adjust the zoom by navigating to **Display > Image Adjustment > Adjust Zoom / Adjust Position**.

HOW CAN I FIX A DISTORTED IMAGE?

Enter keystone correction by navigating to **Settings > Display > Keystone Correction**. Try to fix the image with Four Point correction first. If the image requires further correction, proceed to Eight Point correction.

HOW CAN I FIX A BLURRY IMAGE?

Adjust the focus by navigating to **Settings > Display > Focus**. Press the left or right arrow buttons on the remote until the image becomes clear. For the best picture clarity, use a flat white wall or a professional 80"-150" ambient light-rejecting screen.

HOW DO I PLAY 3D CONTENT ON THE AURORA PRO?

Once you have a 3D video file from your USB flash drive or HDMI source opened, press and hold the Menu button on the remote, select Playback Settings from the Shortcut Menu, and enable 3D. For the best experience, we recommend purchasing 3D glasses separately and wearing them while you watch 3D movies.

WHAT IF THE REMOTE CONTROL DOES NOT WORK?

- The batteries may be drained. Please replace the remote control batteries.
- There may be objects in front of the projector's IR sensor. Please remove the objects.
- The remote may be too far from the projector. Please use the remote within 26 feet of the projector.

HOW DO I CHOOSE THE CORRECT AUDIO OUTPUT?

In the Audio Output settings menu, when you select a speaker, you will see two output options: PCM and RAW.

- With PCM output, the audio source is processed and decoded before it is sent to the speakers. It has wide compatibility, but the sound quality will be altered when compared to the raw audio. PCM is the ideal choice if your speaker does not support end-line decoding, or if you prefer more processed sound quality.
- With RAW output, no processing or decoding is performed on the audio output by the projector, allowing the audio to retain much of the original sound quality. Generally, RAW output is the optimal choice if you have a receiver that is capable of performing the decoding itself.

WHAT IF I CANNOT TURN ON THE PROJECTOR?

- Please check that the device is properly connected to a power source. Press the power button on the device to turn the device on.
- If the projector is hot, please wait for it to cool down before restarting it.
- If these options do not help resolve the issue, please contact NexiGo customer support at cs@nexigo.com.

WHAT IF THE DEVICE DOES NOT SHOW AN IMAGE?

- Power off the device and unplug the power cable. Let the device sit for one minute to allow the capacitors to discharge. Plug it in again after one minute and power on the device.
- The device providing the input source for the projector may not be powered on or connected properly. Please unplug the input device and then reconnect it, ensuring that the connection is solid.
- The input source may be incorrect. In the projector menu, navigate to **Settings > Input source** and select the correct input source you want to connect.

WHAT IF THE IMAGE IS BLURRY?

- Check if the projector is focused properly. In the projector menu, navigate to **Settings > Display** to adjust the focus.
- Ensure the content is presented in high definition (1080p or higher). Non-HD content may appear blurry on a large display.

WHAT IF THE IMAGE IS NOT RECTANGULAR?

In the projector menu, navigate to **Settings > Display** to adjust the image. For additional information, please see the **Image Adjustment** section of this manual.

WHAT IF THE SYSTEM CRASHES OR FREEZES?

- Power off the projector and unplug the power cable. Allow the projector to sit for one minute to allow the capacitors to discharge. Plug it in again after one minute and power it on.

WHAT IF THE PROJECTOR SHUTS OFF BECAUSE OF OVERHEATING?

- Please remove any objects that may be blocking the air vents on the projector. Then restart the projector.
- Move the projector away from heat sources such as air ducts, space heaters, or direct sunlight.



Dolby, Dolby Vision, Dolby Atmos, and the double-D symbol are registered trademarks of Dolby Laboratories Licensing Corporation. Manufactured under license from Dolby Laboratories. Confidential unpublished works. Copyright © 2012-2022 Dolby Laboratories. All rights reserved.

FCC REQUIREMENT

Any changes or modifications not expressly approved by the party responsible for compliance could void the user's authority to operate the equipment.

This device complies with Part 15 of the FCC Rules. Operation is subject to the following two conditions:

- (1) this device may not cause harmful interference, and
- (2) this device must accept any interference received, including interference that may cause undesired operation.

Note: This equipment has been tested and found to comply with the limits for a Class B digital device, pursuant to Part 15 of the FCC Rules. These limits are designed to provide reasonable protection against harmful interference in a residential installation. This equipment generates, uses, and can radiate radio frequency energy, and if not installed and used in accordance with the instructions, may cause harmful interference to radio communications. However, there is no guarantee that interference will not occur in a particular installation. If this equipment does cause harmful interference to radio or television reception, which can be determined by turning the equipment off and on, the user is encouraged to try to correct the interference by one or more of the following measures:

- Reorient or relocate the receiving antenna.
- Increase the separation between the equipment and receiver.
- Connect the equipment into an outlet on a circuit different from that to which the receiver is connected.
- Consult the dealer or an experienced radio / TV technician for help.

This equipment complies with FCC radiation exposure limits set forth for an uncontrolled environment. This equipment should be installed and operated with a minimum distance of 20cm between the radiator & your body. This transmitter must not be co-located or operating in conjunction with any other antenna or transmitter.

CE CONFORMITY FOR EUROPEAN COUNTRIES



EU Compliance Statement: Nexight INC. hereby declares that this device is in compliance with the essential requirements and other relevant provisions of the Directive 2014/53/EU.

A copy of the EU Declaration of Conformity is available online at www.nexigo.com/euro-compliance.

EU contact address: AMZLAB GmbH, Laubenhof 23, 45326 Essen.

NEXIGO

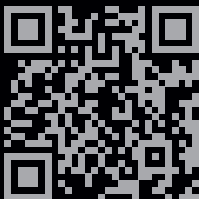

Get in touch with **FREE** online services.
facebook.com/letsnexigo